

PEWO-T-SADDLE

Installation Instruction

Tapping Saddle

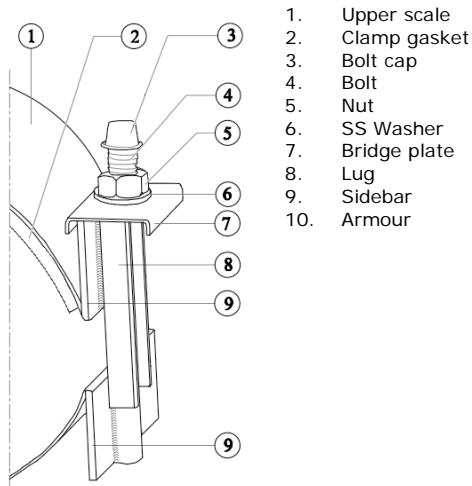

IMPORTANT: Always check that you have a correct and fully functional product before you start any excavations or repairs. When in doubt, take a spare unit with you to avoid delaying the work.

Before installation:

1. Check the diameter of the pipe and make sure you are using correctly sized saddles.
2. Clean the pipe to remove as much dirt and corrosion as possible from the surface. Scrape the pipe to remove dirt and corrosion so that the surface is smooth.
3. Make sure no foreign material sticks to the gasket as it is wrapped around the pipe, nor becomes lodged between gasket and pipe as the nuts are tightened.
4. Keep threads free of foreign material to facilitate tightening.
5. Use a torque wrench to achieve proper torque (step 5).
6. Bolts are often not sufficiently tightened if a torque wrench is not used. Take extra care in this situation to ensure proper tightening.

Installation:

Step 1

Mark the pipe where the ends of the saddle will be. After installation use this mark to confirm that the saddle has been properly positioned.

Step 2

Thoroughly clean the pipe surface area to be covered by the clamp. Apply lubricant to pipe and rubber inside the clamp to ensure a proper seal. **DO NOT use grease!**

Step 3

Back off nuts to end of bolts, but **DO NOT REMOVE THEM**. Place the upper scale on the pipe and bring it into position. At one side the bridge plate of the strap has to be suspended over the lugs. Hinge the suspended strap under the pipe (Fig. 1).

Step 4

Snap the bridge plate ONTO the lugs (Fig. 2). Pull the bridge plates towards each other and tighten the nuts by hand first.

Step 5

Then use a torque wrench with a handle of at least 300 mm in length to tighten the nuts evenly in 20 Nm (Fig. 3).

Recommended torque:
 $< \text{DN } 150: \text{ Max. } 90 \text{ Nm}$
 $\geq \text{DN } 150: \text{ Max. } 110 \text{ Nm}$

Always pressure test for leaks before backfilling the ditch. If leakage occurs repeat step 3, 4 & 5. Then pressure test again.

Step 6

Wait 20 minutes and then retighten to proper torque. Backfill and compact carefully around clamp.

Note: When installed on plastic pipes, please contact your supplier.

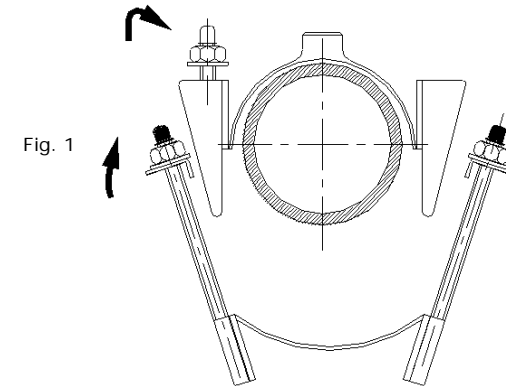

Fig. 1

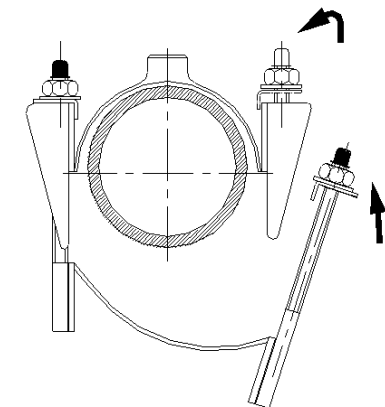

Fig. 2

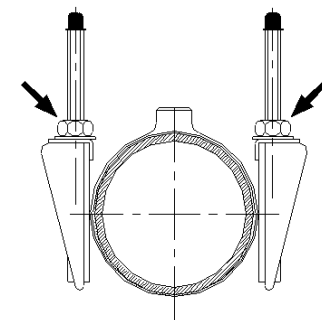

Fig. 3