

PEWO-T-CLAMP-FLANGE Installation instruction Tapping Sleeve Huwa-T

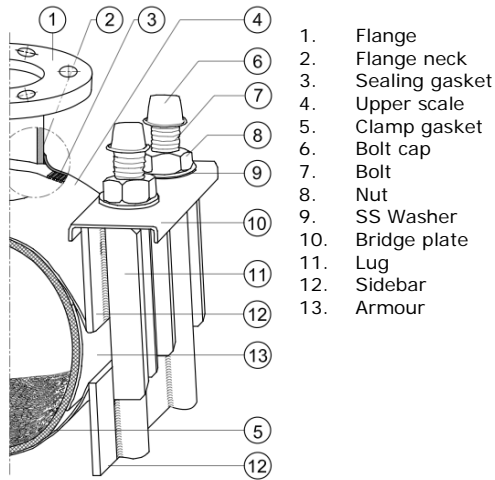

IMPORTANT: Always check that you have a correct and fully functional product before you start any excavations or repairs. When in doubt, take a spare unit with you to avoid delaying the work.

Before installation:

1. Check the diameter of the pipe and make sure you are using a correctly sized product.
2. Make sure that the sealing gasket is fitted evenly around the outlet.
3. Clean the pipe to remove as much dirt and corrosion as possible from the surface. Scrape the pipe to remove dirt and corrosion so that the surface is smooth.
4. Keep threads free of foreign material to facilitate tightening
5. Avoid loose fitting wrenches, or wrenches too short to achieve proper torque on nuts.

pewobar[®]
www.pewobar.de

Installation:

Step 1

Mark the pipe where the ends of the Huwa-T will be.

Step 2

Remove nuts, washers and bridge plates from the bolts.

Step 3

Apply lubricant to pipe and rubber in upper and lower scale.
DO NOT use grease!

Step 4

Place the upper scale with the flange on the pipe and bring it into position (Fig. 1).

Step 5

Bring the lower scale into position (Fig. 2), making sure that the bolts are located between the lugs on the upper scale. Check the gasket edges along the upper and lower scales to be sure they overlap and are not folded over.

Step 6

Make sure the wire ends are properly cleaned too ensure there is no cold welding. Replace the bridge plates, washers and nuts and tighten the nuts by hand (Fig. 3).

Tighten the nuts evenly in the specified order (Fig. 5), starting with 20 Nm up to: 40-60-80-100 to a max. of 120 Nm. Keep checking with a water level whether the flange is in the right position.

The gap between the upper and lower scale on either side should be the same when nuts are not fully torqued (Fig. 6). Torque down all nuts evenly.

Always pressure test for leaks before making a hot tap or backfilling the ditch.
If leakage occurs repeat step 5 and 6. Then pressure test again.

Step 7

Wait 20 minutes and then retighten to proper torque. Backfill and compact carefully around clamp.
If necessary support the SST according to standard codes of practice when heavy accessories are attached to it.

Note: When installed on plastic pipes, please contact your supplier.

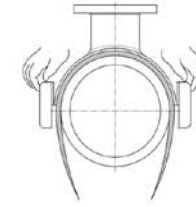

Fig. 1

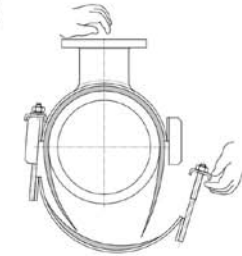

Fig. 2

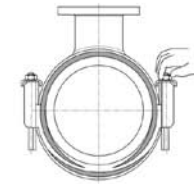

Fig. 3

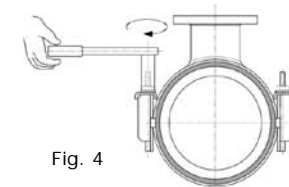

Fig. 4

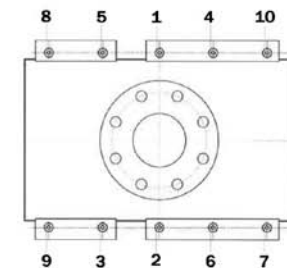

Fig. 5

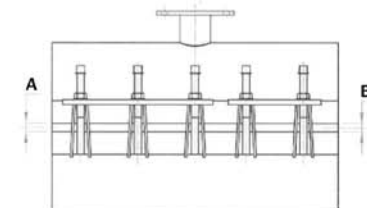

Fig. 6